

Rackgo X Series

JBFA

High Density 2U JBOD with tool-less tray design

User's Guide

Version: 1.2

TABLE OF CONTENTS

Safety Instructions about your system.....	i-vi
Intended Application Uses.....	i-vii
Site Selection.....	i-vii
Equipment Handling Practices.....	i-viii
Power and Electrical Warnings.....	i-viii
System Access Warnings.....	i-viii
Rack Mount Warnings.....	i-ix
Electrostatic Discharge (ESD).....	i-x
Cooling and Airflow.....	i-x
Laser Peripherals or Devices.....	i-x
General Information.....	i-xi
Assembly Safety Guidelines.....	i-xii
Structure of this guide.....	i-xiii

About your JBFA

Introduction.....	1-1
Chassis.....	1-1
Specifications.....	1-1
Package Contents.....	1-3
A Tour of the System.....	1-4
System Overview.....	1-4
System Front View.....	1-5
System Rear View.....	1-6
LED Status Definitions.....	1-7
Sensor Board LED.....	1-7
HDD Status LED.....	1-8
Fan Connector LED.....	1-8

Regulatory & Compliance

Electromagnetic Compatibility Notices.....	2-1
FCC Verification Statement (USA)	2-1
Europe (CE Declaration of Conformity)	2-1
VCCI (Japan).....	2-1
BSMI (Taiwan)	2-1
Regulated Specified Components.....	2-2
Restriction of Hazardous Substances (RoHS) Compliance	2-2
End of Life / Product Recycling.....	2-3
Product Regulatory Compliance Markings.....	2-4

Copyright

Copyright © 2017 Quanta Computer Inc. This publication, including all photographs, illustrations and software, is protected under international copyright laws, with all rights reserved. Neither this manual, nor any of the material contained herein, may be reproduced without the express written consent of the manufacturer. All trademarks and logos are copyrights of their respective owners.

Version 1.2 / 8/22/17

Disclaimer

The information in this document is subject to change without notice. The manufacturer makes no representations or warranties with respect to the contents hereof and specifically disclaims any implied warranties of merchantability or fitness for any particular purpose. Furthermore, the manufacturer reserves the right to revise this publication and to make changes from time to time in the content hereof without obligation of the manufacturer to notify any person of such revision or changes.

For the latest information and updates please refer to www.QCT.io

All the illustrations in this guide are for reference only and are subject to change without prior notice.

About the Guide

This guide is written for users who are viewing the system. This document provides an overview of the hardware features of the chassis and components of the system. For the latest version of this guide, see www.QCT.io.

Conventions

Several different typographic conventions are used throughout this manual. Refer to the following examples for common usage.

Bold type face denotes menu items, buttons and application names.

Italic type face denotes references to other sections, and the names of the folders, menus, programs, and files.

<**Enter**> type face denotes keyboard keys.



WARNING!

Warning information appears before the text it references and should not be ignored as the content may prevent damage to the device.



CAUTION!

CAUTIONS APPEAR BEFORE THE TEXT IT REFERENCES, SIMILAR TO NOTES AND WARNINGS. CAUTIONS, HOWEVER, APPEAR IN CAPITAL LETTERS AND CONTAIN VITAL HEALTH AND SAFETY INFORMATION.

Note:

Highlights general or useful information and tips.

Precautionary Measures

Read all caution and safety statements in this document before performing any of the instructions. To reduce the risk of bodily injury, electrical shock, fire, and equipment damage, read and observe all warnings and precautions in this chapter before installing or maintaining your system. To avoid personal injury or property damage, before you begin installing the product, read, observe, and adhere to all of the following instructions and information. The following symbols may be used throughout this guide and may be marked on the product and / or the product packaging.

Safety Instructions about your system

In the event of a conflict between the information in this guide and information provided with the product or on the website for a particular product, the product documentation takes precedence.

Your system should be integrated and serviced only by technically qualified persons.

You must adhere to the guidelines in this guide and the assembly instructions in related chapters to ensure and maintain compliance with existing product certifications and approvals. Use only the described, regulated components specified in this guide. Use of other products / components will void the UL Listing and other regulatory approvals of the product, and may result in noncompliance with product regulations in the region(s) in which the product is sold.

Table i-1: Warning and Cautions







CAUTION	Indicates the presence of a hazard that may cause minor personal injury or property damage if the CAUTION is ignored.
WARNING	Indicates the presence of a hazard that may result in serious personal injury if the WARNING is ignored.
	Indicates potential hazard if indicated information is ignored.
	Indicates shock hazards that result in serious injury or death if safety instructions are not followed.
	Indicates hot components or surfaces.
	Indicates do not touch fan blades, may result in injury.
	Remove the system from the rack to disconnect the power system.

Table i-1: Warning and Cautions (Continued)

	<p>The rails in the enclosure are designed to carry only the weight of the system sled. Do not use rail-mounted equipment as a workspace. Do not place additional load onto any rail-mounted equipment.</p>
	<p>Indicates two people are required to safely handle the system.</p>
	<p>Restricted Access Location: The system is intended for installation only in a Server Room or Computer Room where both these conditions apply:</p> <ul style="list-style-type: none"> ■ access can only be gained by SERVICE PERSONS or by USERS who have been instructed about the reasons for the restrictions applied to the location and about any precautions that shall be taken; and ■ access is through the use of a TOOL or lock and key, or other means of security, and is controlled by the authority responsible for the location.

Intended Application Uses

This product was evaluated as Information Technology Equipment (ITE), which may be installed in offices, schools, computer rooms, and similar commercial type locations. The suitability of this product for other product categories and environments (such as medical, industrial, residential, alarm systems, and test equipment), other than an ITE application, may require further evaluation.

Site Selection

The system is designed to operate in a typical office environment. Choose a site that is:

- Clean, dry, and free of airborne particles (other than normal room dust).
- Well-ventilated and away from sources of heat including direct sunlight and radiators.
- Away from sources of vibration or physical shock.
- Isolated from strong electromagnetic fields produced by electrical devices.
- In regions that are susceptible to electrical storms, we recommend you plug your system into a surge suppressor and disconnect telecommunication lines to your modem during an electrical storm.
- Provided with a properly grounded wall outlet.
- Provided with sufficient space to access the power system, because they serve as the product's main power disconnect.
- Provided with either two independent DC power system or two independent phases from a single power system.

Equipment Handling Practices

Reduce the risk of personal injury or equipment damage:

- Conform to local occupational health and safety requirements when moving and lifting equipment.
- Use mechanical assistance or other suitable assistance when moving and lifting equipment.
- To reduce the weight for easier handling, remove any easily detachable components.
- Never lift or move your system solely by the handle on the component.

Power and Electrical Warnings



CAUTION!

MAKE SURE THE SYSTEM IS REMOVED FROM THE RACK BEFORE SERVICING ANY NON-HOT PLUG COMPONENTS. THE BUS BAR CLIPS MUST BE DISCONNECTED FROM THE POWER SYSTEM IN ORDER TO FULLY SEPARATE THE SYSTEM FROM THE POWER SOURCE.



CAUTION!

TO AVOID RISK OF ELECTRIC SHOCK, DISCONNECT ALL CABLING FROM THE SYSTEM AND REMOVE THE SYSTEM FROM THE RACK.

System Access Warnings



CAUTION!

TO AVOID PERSONAL INJURY OR PROPERTY DAMAGE, THE FOLLOWING SAFETY INSTRUCTIONS APPLY WHENEVER ACCESSING THE INSIDE OF THE PRODUCT:

- Disconnect from the power source by removing the system from the rack.
- Disconnect all cabling running into the system.
- Retain all screws or other fasteners when servicing. Upon completion servicing, securing with original screws or fasteners.



CAUTION!

IF THE SERVER HAS BEEN RUNNING, ANY INSTALLED HDD MODULES MAY BE HOT.



CAUTION!

UNLESS YOU ARE ADDING OR REMOVING A HOT-PLUG COMPONENT, ALLOW THE SYSTEM TO COOL BEFORE SERVICING.



CAUTION!

TO AVOID INJURY, DO NOT CONTACT MOVING FAN BLADES. IF YOUR SYSTEM IS SUPPLIED WITH A GUARD OVER THE FAN, DO NOT OPERATE THE SYSTEM WITHOUT THE FAN GUARD IN PLACE.

**CAUTION!**

DO NOT MOVE THE RACKS BY YOURSELF. DUE TO THE HEIGHT AND WEIGHT OF THE RACKS, A MINIMUM OF TWO PEOPLE IS REQUIRED TO MOVE THE RACKS.

Rack Mount Warnings

The following installation guidelines are required by UL for maintaining safety compliance when installing your system into a rack.

The equipment rack must be anchored to an unmovable support to prevent it from tipping when your system or piece of equipment is extended from it. The equipment rack must be installed according to the rack manufacturer's instructions.

Install equipment in the rack from the bottom up, with the heaviest equipment at the bottom of the rack.

Extend only one piece of equipment from the rack at a time.

You are responsible for installing a main power disconnect for the entire rack unit. This main disconnect must be readily accessible, and it must be labeled as controlling power to the entire unit, not just to the system(s).

To avoid risk of potential electric shock, a proper safety ground must be implemented for the rack and each piece of equipment installed in it.

Elevated Operating Ambient - If installed in a closed or multi-unit rack assembly, the operating ambient temperature of the rack environment may be greater than room ambient. Therefore, consideration should be given to installing the equipment in an environment compatible with the maximum ambient temperature (T_{ma}) specified by the manufacturer.

Reduced Air Flow - Installation of the equipment in a rack should be such that the amount of air flow required for safe operation of the equipment is not compromised.

Mechanical Loading - Mounting of the equipment in the rack should be such that a hazardous condition is not achieved due to uneven mechanical loading.

Circuit Overloading - Consideration should be given to the connection of the equipment to the supply circuit and the effect that overloading of the circuits might have on over-current protection and supply wiring. Appropriate consideration of equipment nameplate ratings should be used when addressing this concern.

Reliable Earthing - Reliable earthing of rack-mounted equipment should be maintained.

Particular attention should be given to supply connections other than direct connections to the branch circuit (e.g. use of power strips).

Electrostatic Discharge (ESD)



CAUTION!

ESD CAN DAMAGE DRIVES, BOARDS, AND OTHER PARTS. WE RECOMMEND THAT YOU PERFORM ALL PROCEDURES AT AN ESD WORKSTATION. IF ONE IS NOT AVAILABLE, PROVIDE SOME ESD PROTECTION BY WEARING AN ANTI-STATIC WRIST STRAP ATTACHED TO CHASSIS GROUND -- ANY UNPAINTED METAL SURFACE -- ON YOUR SERVER WHEN HANDLING PARTS.

Always handle boards carefully. They can be extremely sensitive to ESD. Hold boards only by their edges without any component and pin touching. After removing a board from its protective wrapper or from the system, place the board component side up on a grounded, static free surface. Use a conductive foam pad if available but not the board wrapper. Do not slide board over any surface.

Cooling and Airflow



CAUTION!

CAREFULLY ROUTE CABLES AS DIRECTED TO MINIMIZE AIRFLOW BLOCKAGE AND COOLING PROBLEMS. FOR PROPER COOLING AND AIRFLOW, OPERATE THE SYSTEM ONLY WITH THE CHASSIS COVERS* / AIR DUCT INSTALLED. OPERATING THE SYSTEM WITHOUT THE COVERS / AIR DUCT IN PLACE CAN DAMAGE SYSTEM PARTS . TO INSTALL THE COVERS* / AIR DUCT:

- Check first to make sure you have not left loose tools or parts inside the system.
- Check that cables, add-in cards, and other components are properly installed.

Attach the covers* / air duct to the chassis according to the product instructions.

* May not apply to all systems.

Please be aware that slots and openings on the front and rear side of the chassis are designed for ventilation; to make sure reliable operation of your system and to protect it from overheating, these openings must not be covered or blocked. The openings should never be covered or blocked by placing the product on a bed, sofa, rug, or other similar surface. This product should never be placed near or over a radiator or heat register, or in a built-in installation unless proper ventilation is provided.

Laser Peripherals or Devices



CAUTION!

TO AVOID RISK OF RADIATION EXPOSURE AND / OR PERSONAL INJURY:

- Do not open the enclosure of any laser peripheral or device.
- Laser peripherals or devices are not serviceable.

Return to manufacturer for servicing.

Use certified and rated Laser Class I for Optical Transceiver product.

Heed safety instructions: Before working with the system, whether using this manual or any other resource as a reference, pay close attention to the safety instructions. Adhere to the assembly instructions in this manual to ensure and maintain compliance with existing product certifications and approvals. Use only the described, regulated components spec-

ified in this manual. Use of other products / components will void the UL listing and other regulatory approvals of the product and will most likely result in non-compliance with product regulations in the region(s) in which the product is sold.

System power on/off: To remove power from system, you must remove the system from rack. Make sure the system is removed from the rack before opening the chassis, adding, or removing any non hot-plug components.

Hazardous conditions, devices and cables: Hazardous electrical conditions may be present on power, telephone, and communication cables. Turn off the system and disconnect the cables attached to the system before opening it. Otherwise, personal injury or equipment damage can result.

Electrostatic discharge (ESD) and ESD protection: ESD can damage drives, boards, and other parts. We recommend that you perform all procedures in this chapter only at an ESD workstation. If one is not available, provide some ESD protection by wearing an antistatic wrist strap attached to chassis ground any unpainted metal surface on the server when handling parts.

ESD and handling boards: Always handle boards carefully. They can be extremely sensitive to electrostatic discharge (ESD). Hold boards only by their edges. After removing a board from its protective wrapper or from the server, place the board component side up on a grounded, static free surface. Use a conductive foam pad if available but not the board wrapper. Do not slide board over any surface.

Installing or removing jumpers: A jumper is a small plastic encased conductor that slips over two jumper pins. Some jumpers have a small tab on top that can be gripped with fingertips or with a pair of fine needle nosed pliers. If the jumpers do not have such a tab, take care when using needle nosed pliers to remove or install a jumper; grip the narrow sides of the jumper with the pliers, never the wide sides. Gripping the wide sides can damage the contacts inside the jumper, causing intermittent problems with the function controlled by that jumper. Take care to grip with, but not squeeze, the pliers or other tool used to remove a jumper, or the pins on the board may bend or break.



General Information

The information about rack and the wording “rack” in this technical guide supports the organization of Open Compute definition.

The term *Rack* as found in this technical guide refers to the term *Rack* or *Open Rack* as described and used in the Open Compute Project definition.

Before servicing this system, it is recommended to read this technical guide completely to be aware of any safety issues or requirements involved in the servicing of this system.

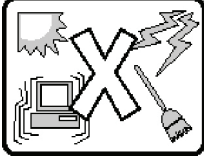
Assembly Safety Guidelines

	<p>The system is designed to operate in a typical office environment.</p> <p>Choose a site that is:</p> <ul style="list-style-type: none"> ● Clean and free of airborne particles (other than normal room dust). ● Well ventilated and away from sources of heat including direct sunlight. ● Away from sources of vibration or physical shock. ● Isolated from strong electromagnetic fields produced by electrical devices. ● In regions that are susceptible to electrical storms, we recommend you plug your system into a surge suppressor and disconnect telecommunication lines to your modem during an electrical storm. ● Provided with a properly grounded wall outlet. ● Provided with sufficient space to access the power system, because they serve as the product's main power disconnect.
	<p>WARNING!</p> <p>The system is safety certified as rack-mounted equipment for use in a server room or computer room, using an approved customer rack.</p> <p>The inner rails are designed to carry only the weight of the system sled. Do not place additional load onto any rail-mounted equipment.</p>
	<p>Heavy object. Indicates two people are required to safely handle the system.</p>

Structure of this guide

- Chapter 1: About your JBFA
“This section introduces the system, its different configuration(s) and the main features.”
- Chapter 2: Regulatory & Compliance
“This section provides regulatory and compliance information applicable to this system.”

About your JBFA

Chapter 1

This section introduces the system, its different configuration(s) and the main features.

1.1 Introduction

High Density 30 hot-swappable HDD

The JBFA is based on Quanta's patented "hidden-shelf" chassis design to fit 30 x 3.5 inch hard disks in a 2OU space.

Lock-in mini-SAS module for better cable management

Serviceability is a key objective for JBFA. With its unique hidden-shelf design and lock-in mini-SAS module design, datacenter operators can swap failed hard disks without adjusting the cables.

Screw-less tray, easy-to-service

Our engineers have overcome the toughest Rotational Vibration Interference (RVI) challenge to bring datacenter operators the all new screw-less hard disk tray design, making failed drive replacement a less time-consuming task.

Chassis

The chassis is a 2OU design for the Open Compute Project rack system. The chassis stands at 536mm (W) x 93.2mm (H) x 800mm (D) with 6 hot-plug fans at rear side.

Specifications

Table 1: System Specifications

SPECIFICATION	DESCRIPTION
Form factor	2OU chassis, flexible design
Chassis dimensions (W x H x D)	<ul style="list-style-type: none"> ● 536mm (W) x 93.2mm (H) x 800mm (D) ● 21.1" (W) x 3.7" (H) x 31.5" (D)
Fan	(6) Hot-swappable dual roter fan modules per system
Weight	<ul style="list-style-type: none"> ● w/o HDD 43 (kg) / 95 (lbs) ● w HDD 62 (kg) / 137 (lbs)
Storage	(30) 3.5" and 2.5" SAS/SATA hot-pluggable HDDs
Controller Module	(2) SAS Interface Modules (SIM)
External I/O Ports	(1) 12Gb/s mini-SAS HD port per SIM
Management Port	(1) OCP debug management port

Table 1: System Specifications (Continued)

SPECIFICATION	DESCRIPTION
LED Indicators	<ul style="list-style-type: none">● HDD Status LED● System Status LED● HDD Active and Fault LED● SAS Interface Module Status LED
Operating Environment	<ul style="list-style-type: none">● Operating temperature: 5°C to 35°C (41°F to 95°F)● Non-operating temperature: -40°C to 65°C (-40°F to 149°F)● Operating relative humidity: 50% to 85%RH● Non-operating relative humidity: 20% to 90%RH
MTBF	<ul style="list-style-type: none">● 100,000 Hours

1.2 Package Contents

- (1) 20U chassis
- (1) Utility CD (User's Guide included)
- (2) External mini-SAS HD cables

1.3 A Tour of the System

System Overview

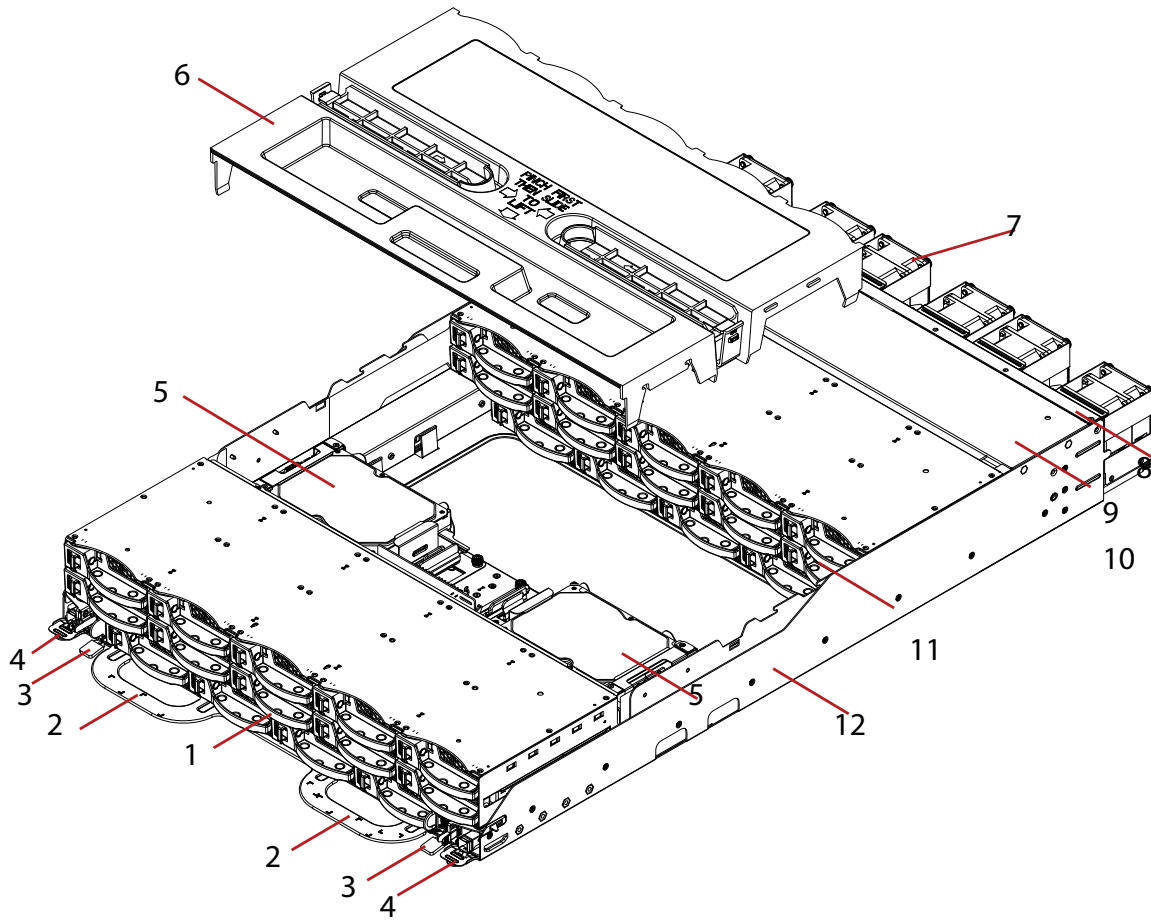

System Component Overview

Table 2: Component Overview

NO.	ITEM	DESCRIPTION
1.	Front HDD bay	Supports up to 14 HDD carriers
2.	Sled tray handle	<ul style="list-style-type: none"> ● Hold to remove the sled assembly from the chassis ● Serial / Product Number label placed
3.	Sled tray release	Push up to unlock the sled assembly from the chassis
4.	Mini-SAS board	<ul style="list-style-type: none"> ● SAS Expander Board (SEB) board to board connection ● HDD Backplane (HDB) for HDD docking
5.	HDD (#14) x 2	Right HDD supports front HDD bay, left supports rear HDD bay. See System Front View for more information.

Table 2: Component Overview (Continued)

No.	ITEM	DESCRIPTION
6.	Air duct	Enclosure to maintain system air flow Open for servicing front SAS expander, front HDD backplane, and Rear HDD bay.
7.	Fan module	(6) hot-pluggable system fan modules
8.	Rear Bracket	Remove to provide access to the Cable Management Arm (CMA) and Power Distribution Board (PDB)
9.	Cable Management Arm (CMA)	Not shown, this item includes the cable management arm unit.
10.	Top Rear Cover	Houses PDB and bus-bar connectors
11.	Rear HDD bay	Supports up to 14 HDD carriers
12.	Chassis	<ul style="list-style-type: none"> • (28+2) x 3.5" HDD carriers • Two HDD backplanes • Two sensor boards • Two SAS expander boards • Two mini-SAS boards • Six fan boards • One power distribution board (not shown)

System Front View

The following view represents the front side (front HDD cage) and inner side (rear HDD cage) of the system.

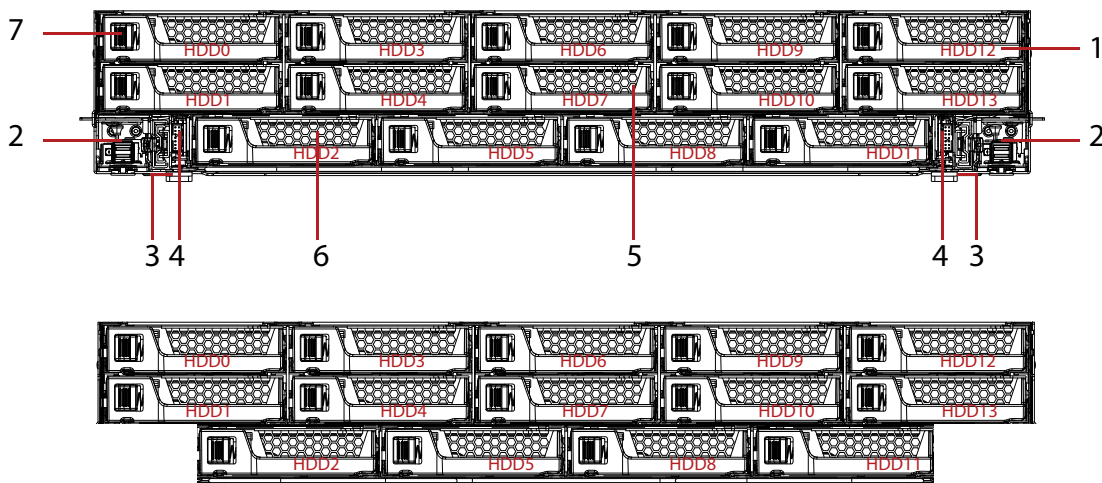

Figure 1-1. System Front View

Table 3: System Front View

No.	NAME	DESCRIPTION
1.	HDD carrier handle	Use to pull the HDD carrier in and out of the HDD bay.
2.	Mini-SAS board	Two mini-SAS boards on each side of the system with one external mini-SAS HD port on the front. Left mini-SAS board: connects to rear HDD Bays Right mini-SAS board: connects to front HDD Bays
3.	Tray release button	Press to unlock the inner rails when fully extended.
4.	Sensor board	Two sensor boards on each side of the system, each include a debug header on the front side. Supports hot-plugging for existing debug cards. left side: connects to SEB connected to Rear HDD Backplane. right side: connects to SEB connected to Front HDD Backplane.
5.	HDD carrier	14 x 3.5" HDD carriers
6.	HDD LED	Display the status of HDD. See <i>HDD Status LED</i> on page 1-8.
7.	HDD carrier release button	Slide and hold to unlock the HDD carrier from the bay.

System Rear View

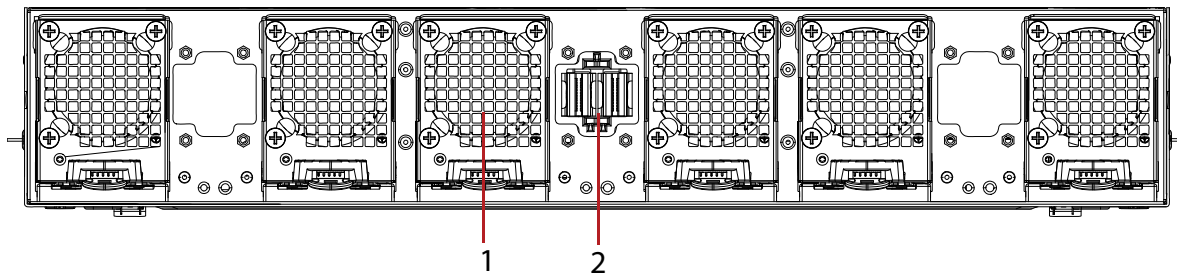

Figure 1-2. System Rear View

Table 4: System Rear View

No.	FEATURE	DESCRIPTION
1.	Air grill	Air grill on hot side
2.	Bus bar connector assembly	Single connector assembly design. The assembly comprises of a floating self-aligning carrier plate, which is connected to the power distribution board (PDB)

LED Status Definitions

Sensor Board LED

Each sensor board (2) includes two LEDs located on the front side of the board.

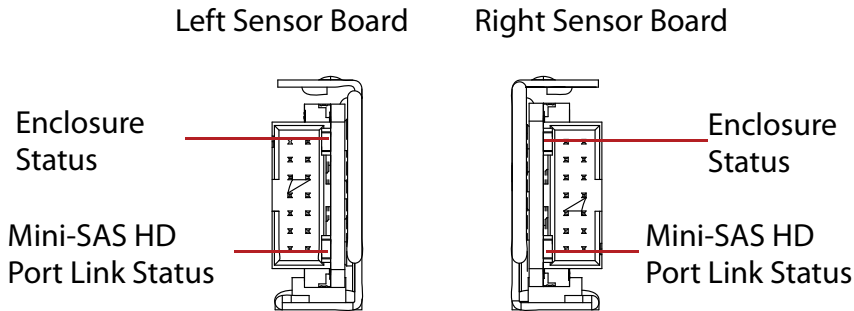

Mini-SAS HD Port Link & Enclosure Status LEDs

Left Sensor Board

The left sensor board supports two LEDs, enclosure and mini-SAS HD port link status LEDs. The enclosure status LED provides disk fault event notification for the rear HDD bay. The mini-SAS HD port link status provides link status for the external mini-SAS HD ports, located on the front of the left mini-SAS board.

Table 5: Left Sensor Board: mini-SAS HD Port Link & Enclosure Status LED Description

NAME	CONDITION	DESCRIPTION
Mini-SAS Port Link Status	On Blue	SAS Link health
	On Red	Loss of SAS link
	Off	No SAS link
Enclosure Status	On Blue	Normal system operation
	On Red	HDD fault: HDD in rear HDD bay Thermal, voltage, disk, and fan fault: system wide

Right Sensor Board

The right sensor board supports two LEDs, enclosure and mini-SAS HD port link status LEDs. The enclosure status LED provides status, critical and non-critical thermal, fan, voltage for the system and disk fault notification for the front HDD bay. The mini-SAS HD port

link status provides link status for the external mini-SAS HD port, located on the front of the right mini-SAS board.

Table 6: Right Sensor Board: mini-SAS HD Port Link & Enclosure Status LED Description

NAME	CONDITION	DESCRIPTION
Mini-SAS Port Link Status	On Blue	SAS Link health
	On Red	Loss of SAS link
	Off	No SAS link
Enclosure Status	On Blue	Normal system operation
	On Red	HDD fault: HDD in front HDD bay

HDD Status LED

The HDD LED provides active and fault information for each disk.

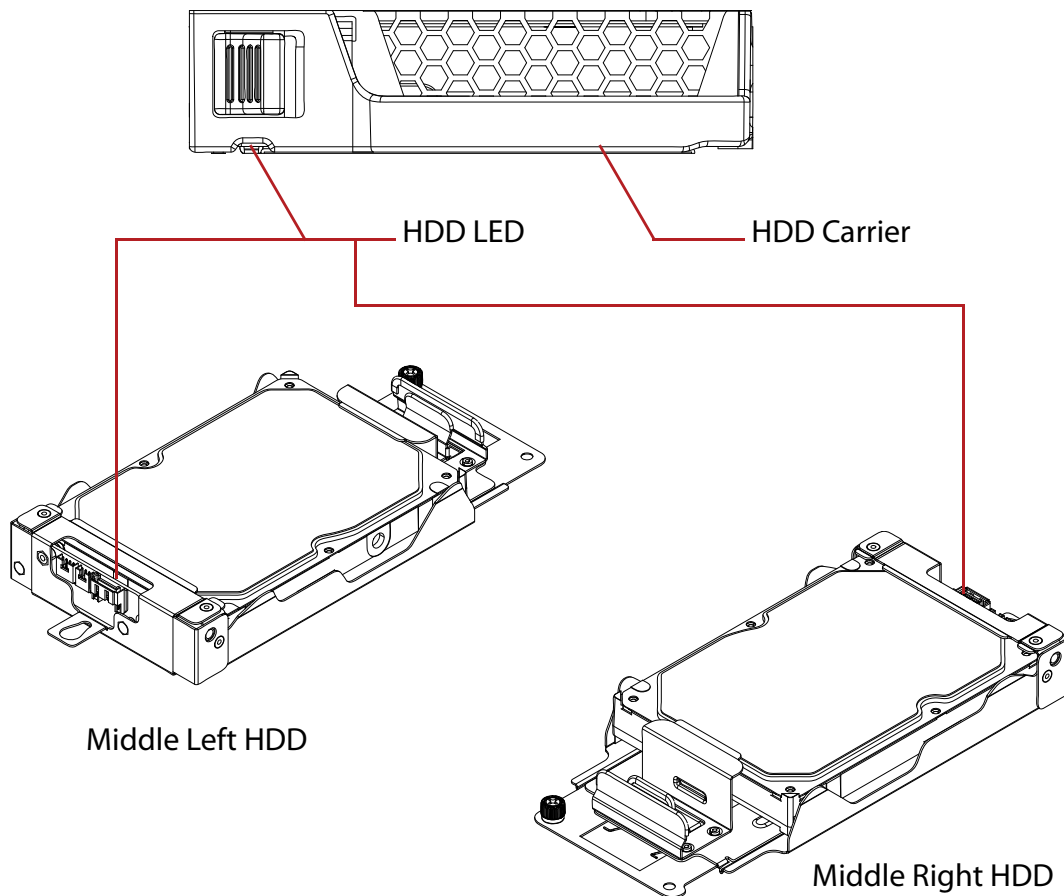

HDD Status LED

Table 7: HDD Status LED Description

NAME	CONDITION
HDD LED Status	HDD Active: Blinking Blue
	HDD Fault: On Red

Fan Connector LED

The fan control board includes normal LED and fault LED for the display of the fan module status.

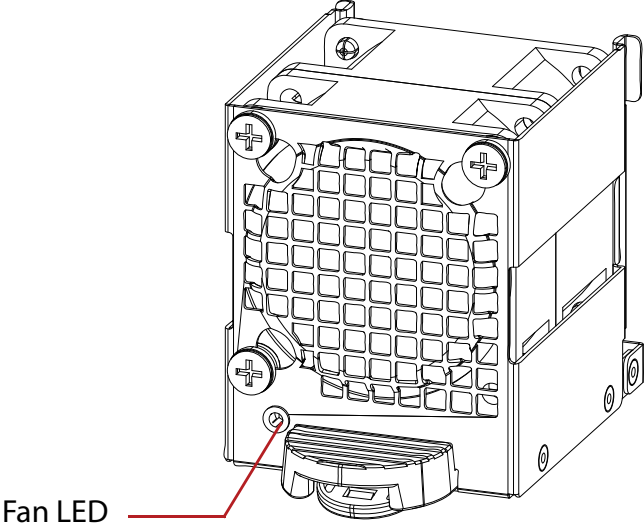

Table 8: Fan Connector Board

NAME	CONDITION
Fan Module Status	Normal Operation: Blue: On
	Fan Fault: On Red

2.1 Electromagnetic Compatibility Notices

FCC Verification Statement (USA)

This device complies with Part 15 of the FCC Rules. Operation is subject to the following two conditions: (1) this device may not cause harmful interference, and (2) this device must accept any interference received, including interference that may cause undesired operation.

This equipment has been tested and found to comply with the limits for a Class A digital device, pursuant to Part 15 of the FCC Rules. These limits are designed to provide reasonable protection against harmful interference when the equipment is operated in a commercial environment. This equipment generates, uses, and can radiate radio frequency energy and, if not installed and used in accordance with the instruction manual, may cause harmful interference to radio communications. Operation of this equipment in a residential area is likely to cause harmful interference, in which case the user will be required to correct the interference at his own expense.

Europe (CE Declaration of Conformity)

This product has been tested in accordance too, and complies with the Low Voltage Directive (2006/95/EC) and EMC Directive (2004/108/EC). The product has been marked with the CE Mark to illustrate its compliance.

VCCI (Japan)

この装置は、クラス A 情報技術装置です。この装置を家庭環境で使用すると電波妨害を引き起こすことがあります。この場合には使用者が適切な対策を講ずるよう要求されることがあります。

VCCI-A

English translation of the notice above:

This is a Class A product based on the standard of the Voluntary Control Council for Interference (VCCI) from Information Technology Equipment. If this is used near a radio or television receiver in a domestic environment, it may cause radio interference. Install and use the equipment according to the instruction guide.

BSMI (Taiwan)

The BSMI Certification Marking and EMC warning is located on the outside rear area of the product

警告使用者：

此為甲類資訊技術設備，於居住環境中使用時，可能會造成射頻擾動，在此種情況下，使用者會被要求採取某些適當的對策。

Regulated Specified Components

To maintain the UL listing and compliance to other regulatory certifications and/or declarations, the following regulated components must be used and conditions adhered to. Interchanging or use of other component will void the UL listing and other product certifications and approvals.

Updated product information for configurations can be found on the site at the following URL: <http://www.QCT.io>

If you do not have access to the Web address, please contact your local representative.

- Add-in cards: must have a printed wiring board flammability rating of minimum UL94V-1. Add-in cards containing external power connectors and/or lithium batteries must be UL recognized or UL listed. Any add-in card containing modem telecommunication circuitry must be UL listed. In addition, the modem must have the appropriate telecommunications, safety, and EMC approvals for the region in which it is sold.
- Peripheral Storage Devices: must be UL recognized or UL listed accessory and TUV or VDE licensed. Maximum power rating of any one device is 19 watts. Total server configuration is not to exceed the maximum loading conditions of the power supply.

Restriction of Hazardous Substances (RoHS) Compliance

Quanta[®] Computer Inc. has a system in place to restrict the use of banned substances in accordance with the European Directive 2011/65/EU. Compliance is based on declaration that materials banned in the RoHS Directive are either (1) below all applicable threshold limits or (2) an approved / pending RoHS exemption applies.

RoHS implementation details are not fully defined and may change.

Threshold limits and banned substances are noted below:

- Quantity limit of 0.1% by mass (1000 PPM) for:
 - Lead
 - Mercury
 - Hexavalent Chromium
 - Polybrominated Biphenyls Diphenyl Ethers (PBDE)
- Quantity limit of 0.01% by mass (100 PPM) for:
 - Cadmium





End of Life / Product Recycling

Product recycling and end-of-life take-back systems and requirements vary by country. Contact the retailer or distributor of this product for information about product recycling and / or take-back.

2.2 Product Regulatory Compliance Markings

This product is marked with the following product certification markings:

Table 1: Product Regulatory Compliance Markings

REGULATORY COMPLIANCE	REGION	MARKING
UL Recognized Marks	USA / Canada	
CE Mark	Europe	
FCC Marking (Class A)	USA	This device complies with Part 15 of the FCC Rules. Operation of this device is subject to the following two conditions: (1) This device may not cause harmful interference, and (2) This device must accept any interference received, including interference that may cause undesired operation.
VCCI Marking (Class A)	Japan	この装置は、クラス A 情報技術装置です。この装置を家庭環境で使用すると電波妨害を引き起こすことがあります。この場合には使用者が適切な対策を講ずるよう要求されることがあります。 VCCI-A
BSMI Certification Number & Class A Warning	Taiwan	 警告使用者： 此為甲類資訊技術設備，於居住環境中使用時，可能會造成射頻擾動，在此種情況下，使用者會被要求採取某些適當的對策。
ICES	Canada	CAN ICES-3(A)/NMB-3(A)
Recycling Package Mark	Other than China	
EAC Marking	Russia	